

1. THIS DRAWING IS TO BE READ IN CONJUNCTION WITH THE SPECIFICATIONS AND ALL RELEVANT ARCHITECTS' AND SERVICES. DO NOT SCALE. USE FIGURED DIMENSIONS ONLY. ALL LEVELS TO BE CHECKED ON SITE BY THE CONTRACTOR AND ANY PRIOR TO CONSTRUCTION. ALL LEVELS ARE TO ORDNANCE DATUM MAIN HEAD.

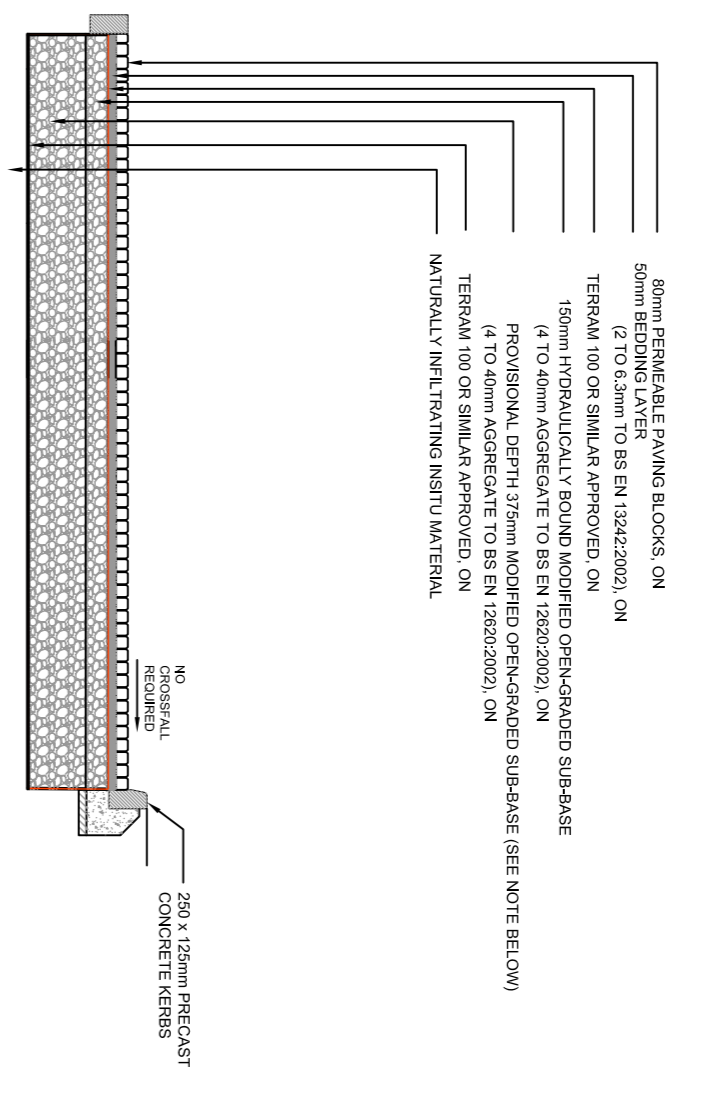

TYPICAL SECTION THRU COMMERCIAL PERMEABLE PARKING
SCALE 1:50

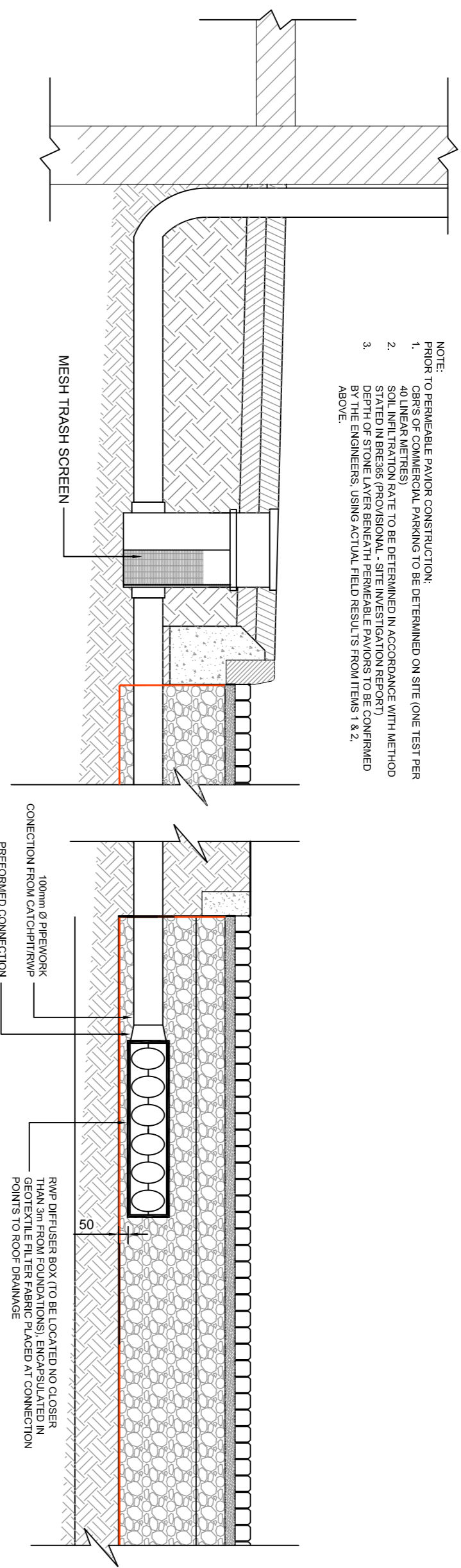

SCHEMATIC SHOWING RWP TO PERMEABLE PAVIORS - COMMERCIAL AREA
SCALE 1:25

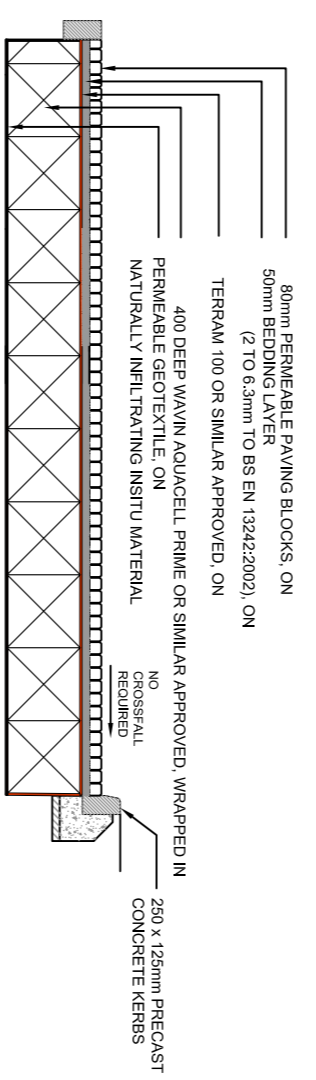

TYPICAL SECTION THRU PRIVATE PERMEABLE PARKING
SCALE 1:50

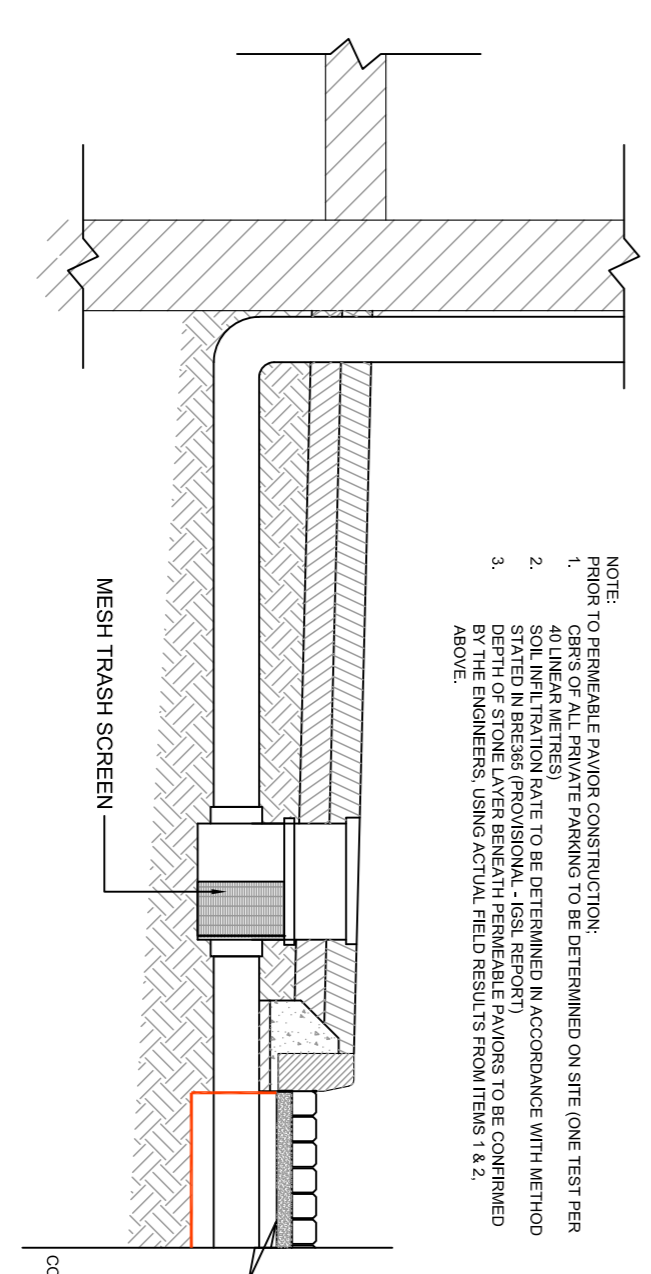

SCHEMATIC SHOWING RWP TO PERMEABLE PAVIORS - PRIVATE
SCALE 1:25

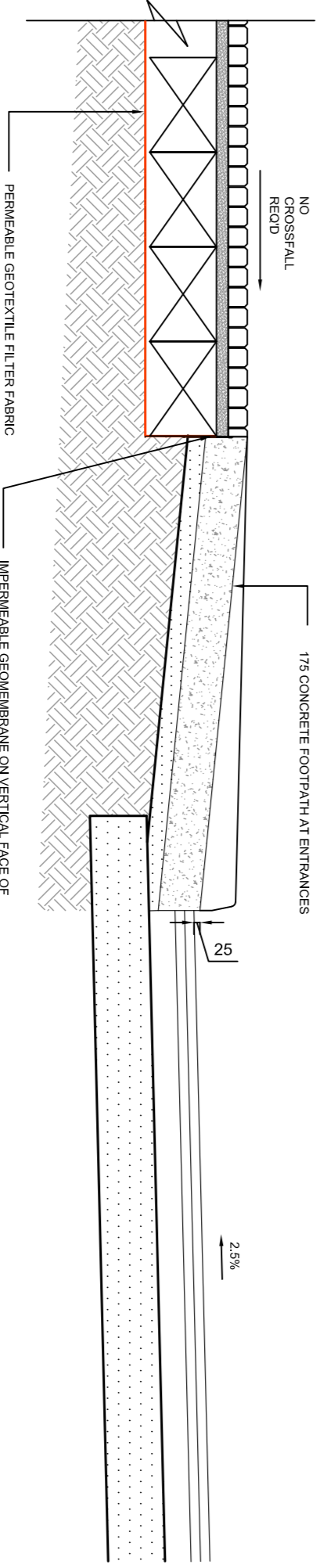

PERMEABLE PAVIOR-FOOTPATH/ROAD INTERFACE DETAIL - PRIVATE
SCALE 1:25

NOTE:
1. PRIOR TO PERMEABLE PAVING CONSTRUCTION, 40mm BEDDING TO BE DETERMINED ON SITE (ONE TEST PER 40m² AREA).
2. 100mm AGGREGATE TO BE DETERMINED ON SITE (ONE TEST PER 40m² AREA).
3. 150mm GEOTEXTILE TO BE DETERMINED ON SITE (ONE TEST PER 40m² AREA).
4. 100mm PERMEABLE PAVING BLOCKS TO BE DETERMINED ON SITE (ONE TEST PER 40m² AREA).
5. 250 x 150mm PRECAST CONCRETE KERBS TO BE DETERMINED ON SITE (ONE TEST PER 40m² AREA).
6. MESH TRASH SCREEN TO BE DETERMINED ON SITE (ONE TEST PER 40m² AREA).

NOTE:
1. PRIOR TO PERMEABLE PAVING CONSTRUCTION, 40mm BEDDING TO BE DETERMINED ON SITE (ONE TEST PER 40m² AREA).
2. 100mm AGGREGATE TO BE DETERMINED ON SITE (ONE TEST PER 40m² AREA).
3. 150mm GEOTEXTILE TO BE DETERMINED ON SITE (ONE TEST PER 40m² AREA).
4. 100mm PERMEABLE PAVING BLOCKS TO BE DETERMINED ON SITE (ONE TEST PER 40m² AREA).
5. 250 x 150mm PRECAST CONCRETE KERBS TO BE DETERMINED ON SITE (ONE TEST PER 40m² AREA).
6. MESH TRASH SCREEN TO BE DETERMINED ON SITE (ONE TEST PER 40m² AREA).

GARLAND
L. M. R. K. V. A. T. E. R. F. O. R. D. I. N. T. E. R. N. A. T. I. O. N. A. L. A. R. C. H. I. T. E. C. T. S.
D. U. B. 155, 4th Floor, 155, Market Street, Ballinacorney, Dublin 15, Ireland
E: info@garlandconsultancy.com W: www.garlandconsultancy.com

PROJECT: RESIDENTIAL AND NEIGHBOURHOOD CENTRE DEVELOPMENT (PHASE 1)
ARCHITECT: RMD ARCHITECTS
CLIENT: BALLMOUNT PROPERTIES LTD.
REV. DATE: DESCRIPTION: DWG. APP. BY: DATE: 032 1st

STATUS: **PLANNING APPLICATION**
DRAWN: AMI DES. BY: AMI
CHK. BY: JN APP. BY: KR
DATE: 02/08/17 JOB NO. R1831
A1 SCALE: 150, 1:25 @ A1
Dwg. No. 032